

Hydro Mount DL

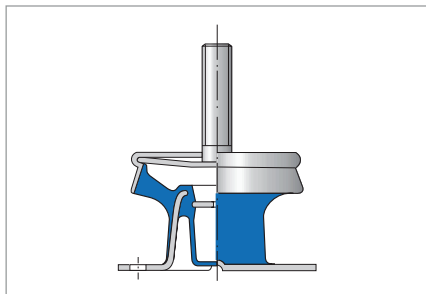

Fig. 1 Hydro Mount DL

Material

Standard material	Hardness
Natural rubber NR 11	40, 45, 50, 55, 60, 65 Shore A

Operating conditions

Compressive forces in Z direction	700 N ... 1700 N	Maximum permissible force
Max. temperature	+60 °C, transient +80 °C	
Min. temperature	-45 °C	

Product description

The hydro mount, as a hydraulically damping rubber mount, solved the designer's conflict of how to mount a mass that is excited by wide frequency spectrum. Particularly if low frequencies – between 5 Hz and 15 Hz – can occur as the excitation frequency, on the one hand high damping in the natural frequency range of the system, and on the other, a good isolation property above this natural frequency (supercritical mounting) is necessary.

Product advantages

- Frequency & amplitude selective damping
- Cross-stiffness
- Integrated capability for levelling the load
- HD version for "extra-hard" use
- RoHS-compliant.

Application

Hydro Mounts DL are suitable for use as mounts for pumps, compressors and engines in utility vehicles and in boats and for vehicle superstructures, particularly driver's cabs.

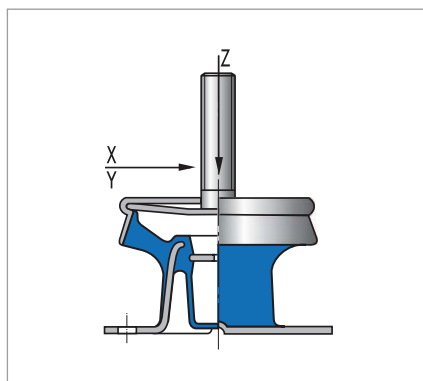

Fig. 2 Primary load directions

Hydro Mounts DL are predominantly used in vehicles of all types. In these applications the related assembly must be mounted as softly as possible to achieve a good structure-borne sound isolation. At low frequencies near the natural frequency of the spring-mass system engine/engine mounts, such soft mounting results in inadmissibly high amplitudes at the motor. Hydro Mounts DL have a soft spring characteristic and thus a large static deflection.

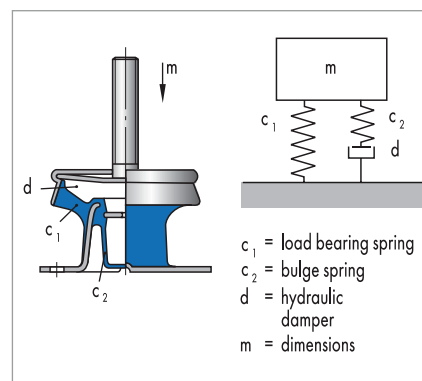

Fig. 3 Mode of operation

The hydraulic mechanism with frequency and amplitude dependent damping integrated in the mount is designed for effect in the Z direction. By matching the damping maximum of the mount to the critical frequency (resonance frequency) of the spring-supported mass, the resonance magnification can be noticeably reduced. For higher frequencies, the insulating capability of elastomer bond components can be utilised. These hydro mounts have a greater flexibility in the Z direction than in the X,Y direction. Hydro mounts are designed for primary loading in the axial as well as radial direction but they can also withstand cardanic deformation. The longitudinal axis should be selected for the introduction of the static primary load.

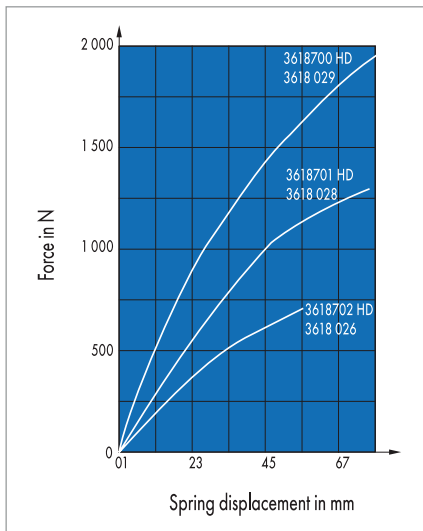

Fig. 4 Static spring characteristic curve in Z direction

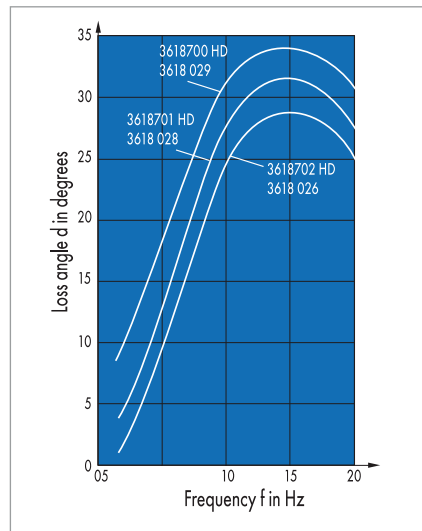

Fig. 5 Transient of the loss angle as a function of frequency

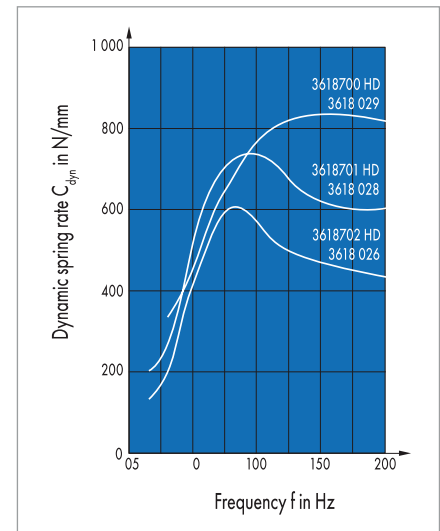

Fig. 6 Dynamic spring rate as a function of frequency

Design notes

The mount configuration comprises a conical mount with integrally moulded/integral expansion bellows with threaded stud. The expansion bellows is filled with a special fluid. A control plate is located between the expansion bellows and the securing plate for setting of the specific hydraulic damping characteristics.

Fitting & installation

- Hydro mounts are designed to be secured by means of the threaded fastener with securing plate assembly and the flange of the conical mount
- Individual components permit slight adjustment to allow for in-situ offset or angular offset
- It is important to ensure that the mating faces of the frame and the mass carried by the mount are flat and smooth
- In particular, the area underneath the flange mount must be free of sharp edges, burrs and filings, so that the rubber element can expand on it without risk of damage
- Position the mount relative to the static load in such a way that securing plate and flange are preloaded relative to each other
- Use HD-rated hydro mounts by preference for applications with extra-harsh conditions characterised by many hard shock loads: fork-lift trucks running on solid-rubber tyres is a typical example.

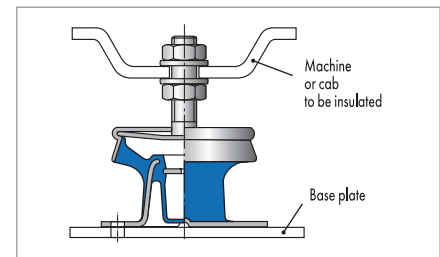

Fig. 7 Fitting & installation instructions: Hydro Mount DL

Article list

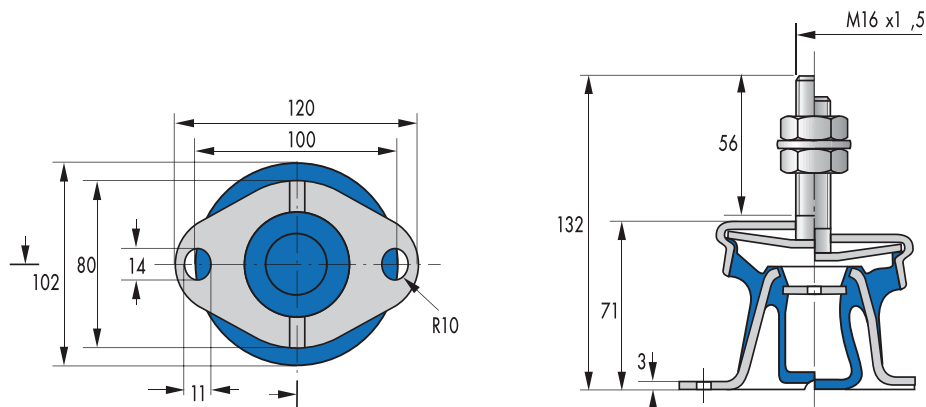

Fig. 8 Hydro Mounts DL 036 18 026, 036 18 028, 036 18 029, 036 18 700, 036 18 701, 036 18 702

Nominal values of the maximum amounts		Stiffness			Product No.	Material	Type	Article No.	
Axial pressure		Radial shear		Axial pressure					
F _z max	s _z max	c _x	c _y	c _z					
		s _z = 5mm	s _z = 5mm	s _z = 2,5mm					
[N]	[mm]	[N/mm]	[N/mm]	[N/mm]					
700	5,0	143	143	142	036 18 026	50 NR 11	-	93638	●
1200	5,6	200	200	243	036 18 028	55 NR 11	-	93639	●
1700	5,4	230	230	350	036 18 029	60 NR 11	-	93640	●
700	5,0	143	143	142	036 18 702	50 NR 11	HD	49022858	●
1200	5,6	200	200	243	036 18 701	55 NR 11	HD	2129442	●
1700	5,4	230	230	350	036 18 700	60 NR 11	HD	511065	●

● Available from stock ○ On request: Tool is available, delivery at short notice